

Wirewound Resistors, Flameproof, Bath-tub Type (High Power with Aluminum Case Type)

Type: **ERF□□□W**

ERF60W, ERF100W, ERF150W, ERF200W



■ Features

- FlameproofMade from nonflammable materials, making the resistor very safe.
- Exclusive Pulse.....Suited for regeneration resistance, due to a structure and materials equipped for pulse characteristics.
- Uniform Quality.....An exclusive automated process with a meticulous quality-control system, combining fine selections of resistance wires and associated qualified materials resulting in uniform quality and consistent reliability.

■ Explanation of Part Numbers

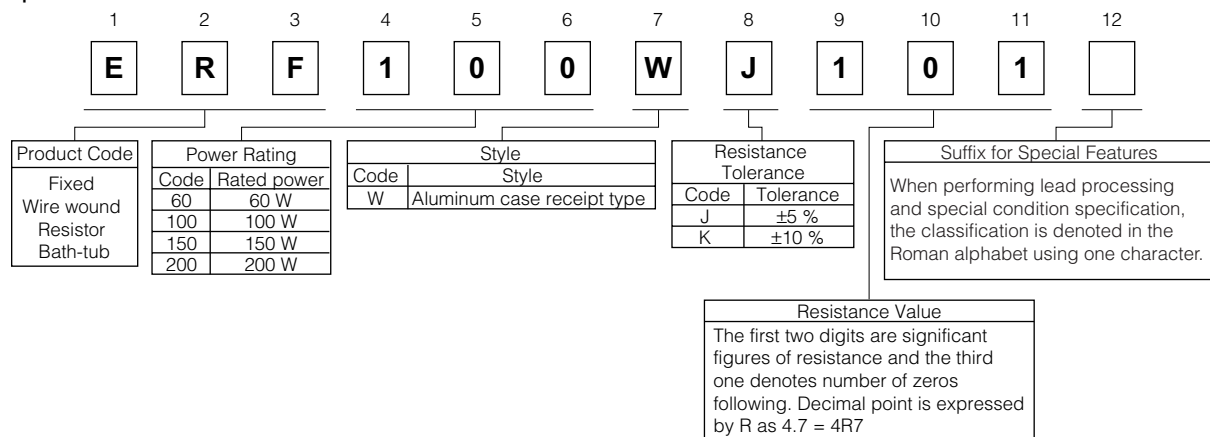

■ Construction

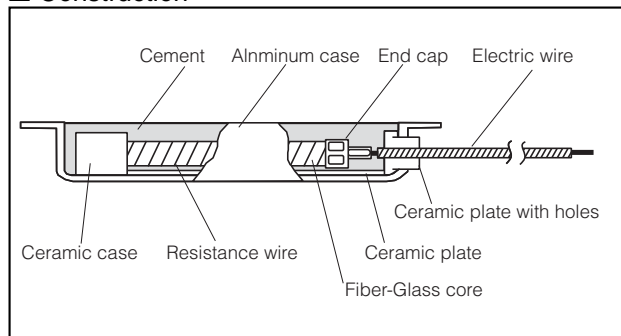

■ Dimensions in mm (not to scale)

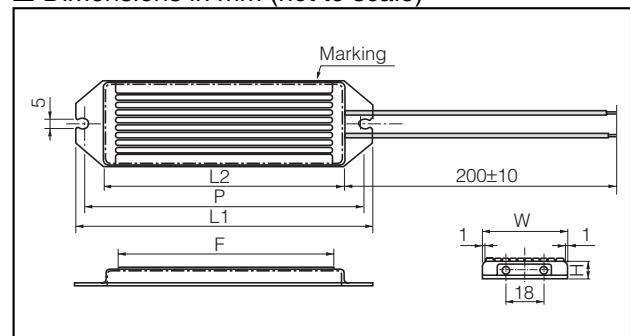

■ Ratings

Type	Power*1 Rating at 25 °C (W)	Resistance Range (Ω)		Dielectric Withstanding Voltage (VAC)	Standard Quantity (pcs.)
		min.	max.		
ERF60W	60	1.2	450	2000	50
ERF100W	100	8.2	910	2000	50
ERF150W	150	11.0	1.2 k	2000	50
ERF200W	200	15.0	1.6 k	2000	50

*1 ; Classis Mounted (300×300×2t Al plate)

Type	Dimensions (mm)					
	L1	L2	W	H	P	F
ERF60W	100	75	30	13	90	67
ERF100W	152	120	44	13	140	112
ERF150W	182	150	44	13	170	134
ERF200W	230	200	44	13	220	184

■ Packaging Methods

Please contact the factory for packaging methods

Safety Precautions

The following are precautions for individual products. Please also refer to the precautions common to Fixed Resistors shown on page ER3 of this catalog.

1. Since Wirewound Resistors (hereafter called the resistors) generate heat during use, mount them on your product and carefully check the effect of heat on other components. Provide for adequate safety when designing your product. Otherwise, when a short circuit or other abnormality occurs, or when a voltage or current exceeding the rating is applied, the resistors may overheat without breaking, or may generate smoke or red-heat, breaking the ceramic case and thus exposing the red-heating resistor element.
2. Carefully check the inductance effect of the resistors when using them in a high-frequency circuit.
3. If a transient load (heavy load in a short time) like a pulse is expected to be applied, check and evaluate the operations of the resistors when installed in your products under the most adverse conditions before use.

Safety Precautions (Common precautions for Fixed Resistors)

- When using our products, no matter what sort of equipment they might be used for, be sure to make a written agreement on the specifications with us in advance. The design and specifications in this catalog are subject to change without prior notice.
- Do not use the products beyond the specifications described in this catalog.
- This catalog explains the quality and performance of the products as individual components. Before use, check and evaluate their operations when installed in your products.
- Install the following systems for a failsafe design to ensure safety if these products are to be used in equipment where a defect in these products may cause the loss of human life or other significant damage, such as damage to vehicles (automobile, train, vessel), traffic lights, medical equipment, aerospace equipment, electric heating appliances, combustion/gas equipment, rotating equipment, and disaster/crime prevention equipment.
- * Systems equipped with a protection circuit and a protection device
- * Systems equipped with a redundant circuit or other system to prevent an unsafe status in the event of a single fault

(1) Precautions for use

- These products are designed and manufactured for general and standard use in general electronic equipment (e.g. AV equipment, home electric appliances, office equipment, information and communication equipment)
- These products are not intended for use in the following special conditions. Before using the products, carefully check the effects on their quality and performance, and determine whether or not they can be used.
 1. In liquid, such as water, oil, chemicals, or organic solvent
 2. In direct sunlight, outdoors, or in dust
 3. In salty air or air with a high concentration of corrosive gas, such as Cl₂, H₂S, NH₃, SO₂, or NO₂
 4. Electric Static Discharge (ESD) Environment
 - These components are sensitive to static electricity and can be damaged under static shock (ESD). Please take measures to avoid any of these environments.
 - Smaller components are more sensitive to ESD environment.
 5. Electromagnetic Environment
 - Avoid any environment where strong electromagnetic waves exist.
 6. In an environment where these products cause dew condensation
 7. Sealing or coating of these products or a printed circuit board on which these products are mounted, with resin or other materials
- These products generate Joule heat when energized. Carefully position these products so that their heat will not affect the other components.
- Carefully position these products so that their temperatures will not exceed the category temperature range due to the effects of neighboring heat-generating components. Do not mount or place heat-generating components or inflammables, such as vinyl-coated wires, near these products .
- Note that non-cleaning solder, halogen-based highly active flux, or water-soluble flux may deteriorate the performance or reliability of the products.
- Carefully select a flux cleaning agent for use after soldering. An unsuitable agent may deteriorate the performance or reliability. In particular, when using water or a water-soluble cleaning agent, be careful not to leave water residues. Otherwise, the insulation performance may be deteriorated.

(2) Precautions for storage

The performance of these products, including the solderability, is guaranteed for a year from the date of arrival at your company, provided that they remain packed as they were when delivered and stored at a temperature of 5 °C to 35 °C and a relative humidity of 45 % to 85 %.

Even within the above guarantee periods, do not store these products in the following conditions. Otherwise, their electrical performance and/or solderability may be deteriorated, and the packaging materials (e.g. taping materials) may be deformed or deteriorated, resulting in mounting failures.

1. In salty air or in air with a high concentration of corrosive gas, such as Cl₂, H₂S, NH₃, SO₂, or NO₂
2. In direct sunlight

<Package markings>

Package markings include the product number, quantity, and country of origin. In principle, the country of origin should be indicated in English.